

Technical Manual



MASTER 3 PP multilayer soil system



MASTER

3

PIPELIFE 
pipes for life



MASTER 3 PP MULTILAYER SOIL SYSTEM



CONTAIN

1. PRODUCT INFORMATION

1.1. The 3 layers of MASTER 3	3
1.2. Technical data of MASTER 3	4
1.3. The sound measurements of the MASTER 3	5
1.4. Scope of an application	5
1.5. Special applications	6
1.6. Compatibility	6

2. INSTALLATION

2.1. Transport	6
2.2. Storage	6
2.3. Cutting pipes to length	7
2.4. Joining the pipes and fittings	7
2.5. Fastening and clamp distance	7
2.6. Subsequent Installation of fittings	8
2.7. Ceiling ducts	8
2.8. Installation of pipes in concrete	8
2.9. Installation of pipes in masonry	8
2.10. Transition to cast- or fiber-cement conical end	8
2.11. Transition to cast-sleeve and fiber-cement sleeve	8
2.12. Connection with metal pipes	8

3. PRODUCT RANGE

3.1. Pipes	9
3.2. Fittings	9

COMPANY STANDARD

- Soil pipe system made from 3 layers of polypropylene
- Mineral-reinforced composite, halogen-free
- Minimum stiffness 4 kN/m² (SN4)
- Quiet, glide-enhanced inner layer made from PP-C
- Resistant against hot water up to 95 °C
- Fittings single-layer made from polypropylene PP-CO
- Pipe series S20 tested referring to EN 1451-1
- Pipes and fittings with integrated plug-in sleeve
- Lip seal ring from synthetic rubber inserted at works
- Installation referring to EN 1451, EN 12056 and our guide
- Overall lengths: 0,15; 0,25; 0,50; 1,0; 1,5; 2,0 m in DN 32-150, 2,65 m in DN 70, 100, 125, 150

1. PRODUCT INFORMATION

1.1. The 3 layers of MASTER 3

The new Pipelife MASTER 3 soil pipe consists of three optimally adapted layers. It fulfils all demands that can be made of modern soil pipe systems in modern houses and residential buildings as well as in industrial structures.

The smooth inner layer prevents incrustation and is also partly responsible for the good **sound absorbing characteristics**.

The solid middle layer provides a **high degree of stiffness** and ensures especial robustness.

The reddish brown outer layer provides **excellent impact resistance** – even at low temperatures.

Each layer has its own special influence on the characteristics of the pipe.

The smooth inner layer

constructed of Polypropylene Copolymer (PP-CO)

- No separation of the water column -> low noise development
- Signal white for optimum camera inspection
- High discharge rate

The solid middle layer

constructed of mineral enhanced polypropylene (PP-MV)

- High degree of ring and longitudinal stiffness
- Good sound absorbing characteristics
- High degree of dimensional stability

The impact resistant outer layer

constructed of Polypropylene Copolymer (PP-CO)

- Particularly robust
- No socket fractures
- Safe installation even at low temperatures ❄️

The interaction of the three layers and their special characteristics ensure that the MASTER 3 piping system possesses a **multitude of positive characteristics**:

- + **High degree of ring and longitudinal stiffness**
- + **High discharge rate**
- + **Excellent sound insulation**
- + **High impact resistance**
- + **Long life**

RESULTING IN TOP PRODUCT QUALITY!

Only the highest raw material quality is used for MASTER 3. State of the art technology 3-layer extrusion and socket processing ensures a particularly good fit and sealing. You can rely on the experience and reliability of a noted Pipelife manufacturer.





1.2. Technical data of MASTER 3

MATERIAL

Pipe: PP-CO / PP-MV / PP-CO
 Fittings: PP-H
 Sealing ring: Elastomer out of Styrol – Butadien – Caoutchouc (SBR)

COLOR

Outer layer RAL 8012 reddish brown
 Middle layer RAL 9011 graphite black
 Inner layer RAL 9003 signal white

CLASSIFICATION OF USE

Pipe BD
 Fitting B

MARKING

The pipes are marked clearly visible and permanently with the name of the firm, date, time, production line, name of the product, the rigidity class, the ice crystal, the outside diameter, wall thickness, overall length, the material, the inspection number as well as with an EAN Code.

The fittings are marked clearly and permanently with the name of the firm, material, article code, outside diameter, the pipe series as well as with the number of the standard.

TEMPERATURE RESISTANCE FOLLOWING EN 1451-1

Long-term temperature resistance: max. 95 °C

CHEMICAL RESISTANCE

MASTER 3 is resistant to acids and alkalis ranging from pH 2 to pH 12

FIRE CLASSIFICATION ACCORDING TO EN 13501- 1

Behavior in fire – smoke development – burning dripping/falling D – s2, d2

ICE CRYSTAL SYMBOL

MASTER 3 soil pipes correspond to the enhanced requirement of impact resistance. They are also suitable for installation at temperatures -10 °C.

STANDARDS

MASTER 3 pipes are tested based on the EN 1451 Part 1. Fittings are tested according to EN 1451 – 1.

TESTS

The tests according to the standard EN 1451-1 were carried out by OFI Technology GmbH, an internationally accredited testing and inspection institute.

RIGIDITY

Pipe rigidity class SN4 ($\geq 4.0 \text{ kN/m}^2$)
 Fittings pipe series S20

PHYSICAL PROPERTIES:

Description	Unit	Value	Standard
Mean density	kg/dm ³	1,1 - 1,2	EN ISO 1183
Melt-flow index range 0,3	g/10 min	0,3 - 0,5	ISO 1133
Limit of elasticity	MPa	>23	ISO 527-2
Moduls of elasticity	MPa	>2200	ISO 527-2
Elongation at break	%	>350	EN ISO 6259

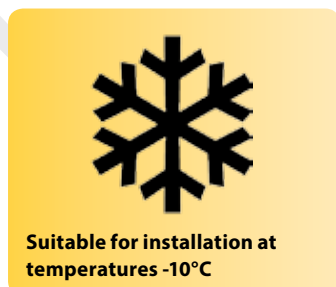
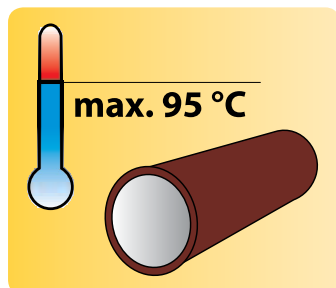

1.3. The sound measurements of the system MASTER 3

Pipelife has subjected its MASTER 3 System to extensive sound measurements according to DIN EN 14366 at the Fraunhofer Institute in Stuttgart (Test Report P – BA 53/ 2007).

Measuring arrangement MASTER 3-System at the Fraunhofer Institute in Stuttgart:

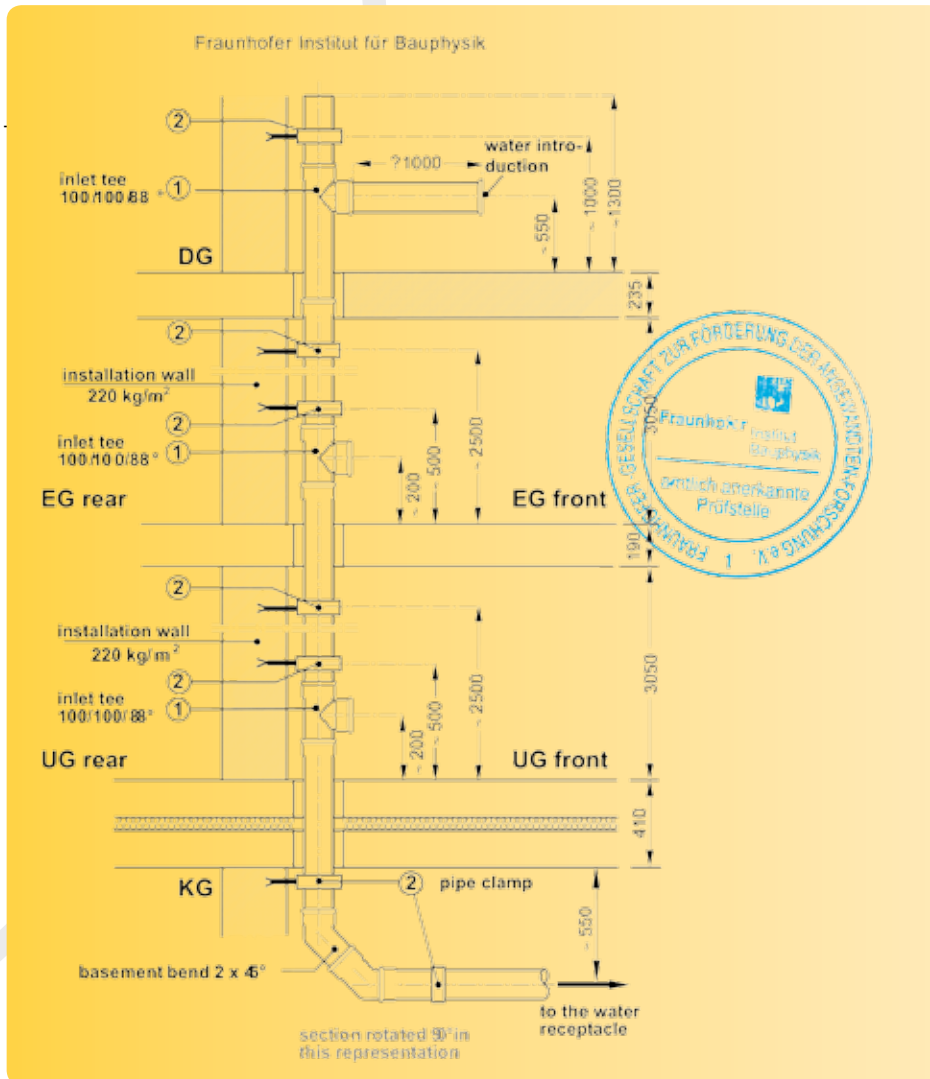

The test was carried out with conventional clip clamps and hanger bolts, as are used in practice.

The values achieved during these measurements fulfill the requirements defined in ÖNORM B 8115 – 2 for the **increased sound protection** in domestic installations.

A-rated sound level L_{TN} for MASTER 3 measured at the Fraunhofer Institute in Stuttgart:

System MASTER 3 upper basement rear				
I/sec	0,5	1,0	2,0	4,0
dB (A)	10,5	15,5	18,0	22,9

Installation plan of the sound measurements for the System MASTER 3 at the Fraunhofer Institute in Stuttgart (representation not true to scale, dimensional details in mm).

1.4. Scope of Application

Pipelife MASTER 3 pipes and fittings are mainly used for drainage lines resistant to hot water for domestic and industrial gray, black and rain water.

- in single and multiple family house construction
- in apartment construction
- in renovation construction
- in industrial plants
- in large scale kitchens and laundries
- in schools, universities
- in hotels, convalescent homes
- in infirmaries and many others

Inside these buildings the Pipelife MASTER 3 system can be used for

- individual and collective lines
- downpipes
- bypass lines
- ventilation pipes and
- interior rain water pipes.

For domestic and industrial application

Also suitable for central dust extraction systems

1.5. Special applications

- Pipes for central dust extraction systems
- Pipes, fittings and sealing elements are also suitable for the transportation of chemically aggressive waste water in the range from pH 2 (acidic) to pH 12 (alkaline).

Pipelife MASTER 3 pipes may not be used:

- outside the building structure
- as pipes in the open air (e.g. external rain downpipe)
- for pipes that conduct waste water containing benzene or benzole
- for pipes, on which temperatures over 95 °C can occur due to external influences
- as disposal pipes in chemical works

1.6. Compatibility

The dimensions of the Pipelife MASTER 3 pipes and fittings conform to EN 1451 – 1 and can be combined with other brands which conform to this standard.

2. INSTALLATION

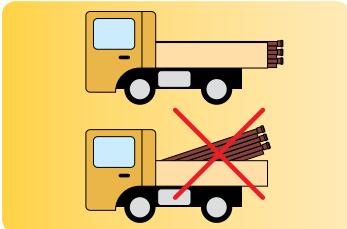

MASTER 3 pipes from Pipelife are tested based on EN 1451 Part 1 and marked with „BD“. The ring stiffness of the SN4 pipes corresponds to at least 4.0 kN/m². The fittings are tested according to EN 1451-1 and correspond to the pipe series S20 and are therefore only intended for use above ground inside buildings.

Pipes and fittings are supplied with integrated plug-in sleeve and inserted lip seal ring.

When using Pipelife MASTER 3 pipes and fittings the EN 12056 is binding with regard to planning and calculation as well as execution.

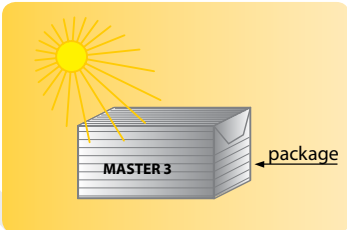

2.1. Transport

It is to be ensured during transport, that the pipes are fully supported over the entire length. The sleeves are thereby to be arranged offset. Pipes protruding out beyond the loading area must be supported in order to avoid bending stresses. The pipes are to be protected against edges (e.g. side and tail gates). Deformation of the pipes is to be avoided.

Carry out loading work with appropriate care. Throwing as well as dragging of the pipes and fittings is to be avoided. This is especially applicable at temperatures below freezing point.

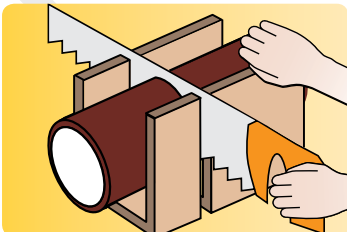

2.2. Storage

The pipes are to be stored standing vertically, protected from dirt and UV in film sacks.

Through suitable modification of the PP-CO outer layer of the MASTER 3 domestic pipes a higher UV-protection is achieved, which enables storage outside. The pipes can therefore also be stored outside unprotected if stored correctly (max. 6 months).

If the pipes are stored horizontally a stacking height of 2 meters should not be exceeded. To avoid sagging of the pipe lengths during storage, the sleeves must be arranged offset. Stacks of pipes are to be secured against rolling apart.

Fittings as well as short overall lengths of 150, 250 and 500 mm are packed in cartons and are to be protected against wetness and damp.



2.3. Cutting pipes to length

When cutting to length or fitting the MASTER 3 soil pipes, these are to be cut off with a pipe cutting and chamfering device or with a fine-toothed saw (panel saw). Thereby mark cut surfaces and if possible use a sawing box or sawing gauge, so that the cuts are produced perpendicular to the pipe axis.

The cut edges are to be deburred inside and outside with a knife or a scraper.

The cut surfaces are to be chamfered below an angle of approx. 15° after cutting to size. If a chamfering device is not used a suitable beveling device or a rasp is to be used for this.

For the length of the bevel refer to the table below. Fittings must not be cut off to length.

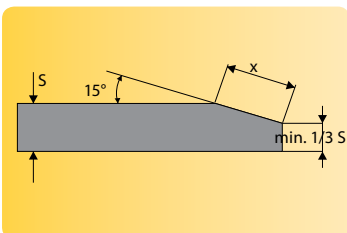

DN	32	40	50	70	100	125	150
x (mm)	4	4	4	4	6	6	7

2.4. Joining the pipes and fittings

The pipes and fittings are joined together with a plug-in socket with lip seal ring inserted at works.

The conical end and the sleeve are to be cleaned of dirt.

The conical end has to be coated thinly with the Pipelife lubricant and pushed into the sleeve up to the stop. Do not use any oils or greases as lubricant.

Now mark the pipe with a suitable marking pen at the edge of the sleeve. The pipe is then pulled out of the sleeve by approx. 10 mm. The plug-in ends of the fittings can be pushed completely into the sleeves. With the vertical arrangement of pipelines the individual pipes are to be secured with pipe clamps immediately after assembly, so that slipping is prevented and the 10 mm expansion length is not nullified.

The distance from the base of the sleeve resulting through the pipe being pulled out is necessary to absorb the change in length caused by heat.

Length expansion coefficient: 0.09 mm/mK (e.g.: Δt 30 °C; Length 2 m = Expansion 5.4 mm).

Gluing the material polypropylene is not possible due to its high resistance to solvents.

2.5. Fastening and clamp distance

The pipes are to be secured with a pipe clamp directly under the pipe sleeve in such a way, that a slipping is prevented during the rest of the assembly. For Pipelife MASTER 3 pipes and fittings only pipe clamps may be used that are coordinated to their outside diameter and surround the pipe completely.

We recommend the use of our clip clamps together with sound insulating elements.

If these are not used, it is recommended to basically only use clamps with suitable padding tapes (not made from soft PVC).

If no padding tape is used with steel clamps, the inner surfaces must be smooth and their edges rounded and free of burrs. Pipe hooks must not be used for fastening.

The distance between the clamps for horizontal lines is maximum 13 times the outside diameter of the pipe and maximum 2 m for downpipes.

In addition there must be a clamp arranged behind each group of fittings immediately after the next sleeve (fixed clamp).

Fixed clamps should prevent the axial movement of the pipeline. They represent fixed points in the pipeline system.

Loose clamps allow a longitudinal movement of the pipelines.

Dimension	32	40	50	70	100	125	150
clamp distance horizontally (m)	0,45	0,55	0,65	0,9	1,45	1,65	2,1
clamp distance vertically (m)	2,0	2,0	2,0	2,0	2,0	2,0	2,0

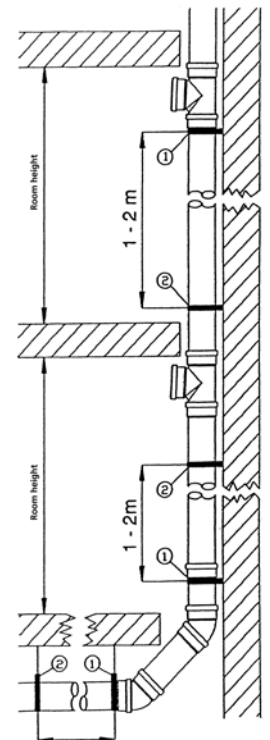

2.6. Subsequent instalation of fittings

a) When using two repair sockets a sufficiently long section of pipe (length of the fitting + 2x pipe outside diameter) is cut out, the pipe ends are deburred and chamfered. The repair socket is pushed over the pipe end over its entire length. Insert fittings and fit the section of pipe into the space remaining. Push second repair socket completely onto the intermediate section. Insert intermediate section and close both gaps by sliding the repair sockets.

b) When using long socket section of pipe corresponding to the length of the fitting plus 1x plug-in depth is cut out of the pipeline. The long socket is pushed in up to the base of the sleeve and then the fitting is inserted using a repair socket. Then push the conical end of the long socket into the fitting sleeve.

2.7. Ceiling ducts

Ceiling ducts are to be produced moisture-proof and sound-insulating. Insofar as a floating screed or poured asphalt is applied to the floor, exposed sections of the pipeline are to be protected by protective tubes or by winding around with heat-insulating materials. With transition to another fire compartment the appropriate fire protection measures are to be taken.

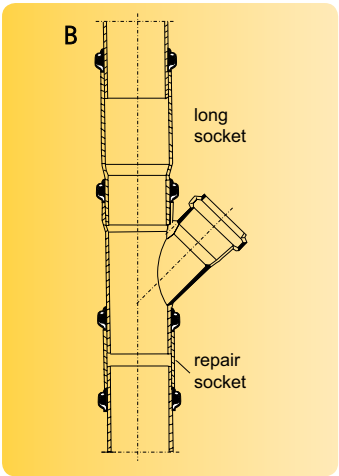
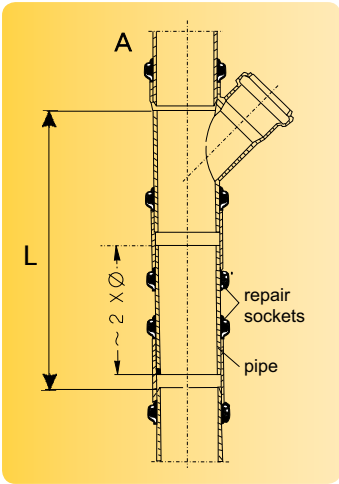

2.8. Instalation of pipes in concrete

Pipelife MASTER 3 pipes and fittings can be installed directly in the screed. The change in length of the pipes is to be taken into account at the sleeves, as described under "Joining the Pipes and Fittings".

The parts of the line are to be secured in such a way, that their position cannot change when the screed is poured. Pipe openings are to be blocked with sleeve stoppers. Sleeve gaps are to be sealed with an adhesive tape or by winding around with a film, so that no cement slurry can penetrate.

The instalation of MASTER 3 pipes in shuttered concrete walls where vibration machines are used is not allowed. Due to the heavy weight of the concrete, here deformation of the pipe can occur.

2.9. Installation of pipes in masonry

Recesses and slits in masonry are only permitted if as a result the statics of the building are not impaired. The masonry slits are to be arranged so that tension-free installation of the pipes can take place.

If the pipes are plastered in directly, i.e. without the use of a plaster base, the pipes must be surrounded with flexible materials such as mineral fiber wool. At places, at which temperatures above 100 °C occur due to external influences, thermal insulating measures must be taken.

2.10. Transition to cast- or fiber-cement conical end

The connection of MASTER 3 sleeves to cast- and fiber-cement conical end is carried out using a ÜFS... transition piece. Sealing area of the seal for conical ends of cast- and fiber-cement pipes.

DN/OD	OF
50	58 - 67 mm
75	78 - 86 mm
110	110 - 116 mm
125	135 - 142 mm
160	160 - 172 mm

2.11. Transition to cast-sleeve and fiber-cement sleeve

The connection of MASTER 3 conical end to cast- or fiber-cement sleeve is carried out using transition piece ÜFM... or ÜFM/GAZ....

2.12. Connection with metal pipes

The connection of siphons and metal pipes to Pipelife MASTER 3 pipes is produced using connector M3-S... or M3-SW....

For this Pipelife has the combi-nipple 5/4", 6/4" in the program. With that the connection of metal pipes of 28-47 mm diameter is possible.

Examples:

Connection of washing basins and sinks, bidets, urinals, laboratory sinks and the like.

The inside of the rubber nipple as well as the metal pipe or the siphon have to be coated with lubricant before assembly in order to make pushing in easy.

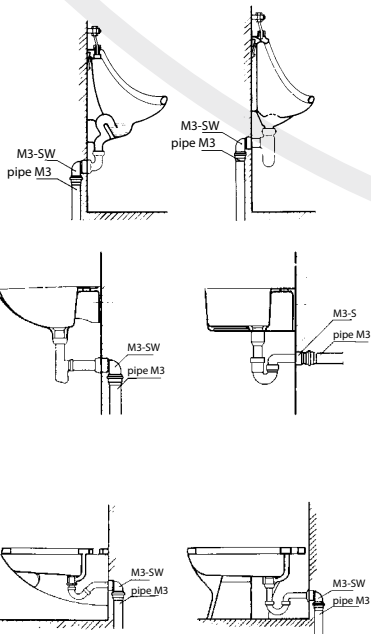

3. PRODUCT RANGE

3.1. Pipes

- Order number **M3.../....**
- with plug-in socket onesided and integrated lip seal ring

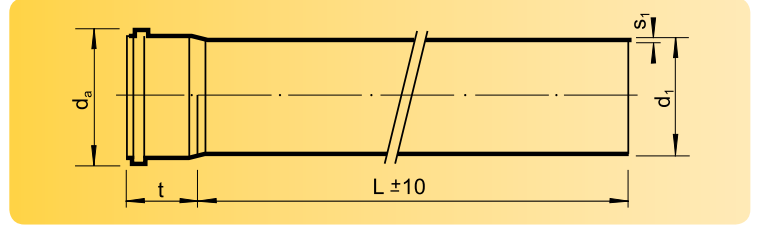

DN	d ₁	s ₁	d _a	t	Weight kg/pcs (mm)						
					150	250	500	1000	1500	2000	2650
32	32	1,8	43,0	55	0,04	0,06	0,12	0,22	0,32	0,42	-
40	40	1,8	54,2	55	0,06	0,08	0,15	0,28	0,41	0,54	-
50	50	1,8	64,2	56	0,07	0,10	0,19	0,35	0,51	0,68	-
70	75	2,1	89,4	61	0,13	0,19	0,33	0,63	0,92	1,21	1,59
100	110	3,0	127,8	76	0,29	0,41	0,72	1,34	1,96	2,57	3,57
125	125	3,5	145,5	82	0,40	0,57	0,98	1,81	2,64	3,47	4,54
150	160	4,4	183,9	100	0,69	0,96	1,63	2,96	4,30	5,63	7,37

3.2. Fittings

MASTER 3 - bend

- Order number **M3-B .../..**
- Fittings with plug-in socket onesided and integrated lip seal ring

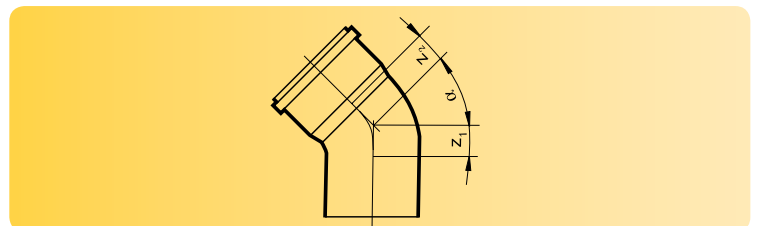

α	15°			30°			45°			67,5°			87,5°		
	DN	z ₁	z ₂	kg/pcs	z ₁	z ₂	kg/pcs	z ₁	z ₂	kg/pcs	z ₁	z ₂	kg/pcs	z ₁	z ₂
32	10	10	0,030	12	12	0,030	15	15	0,030	20	20	0,030	27	27	0,030
40	5	8	0,027	7	11	0,027	10	14	0,029	16	20	0,032	23	26	0,032
50	5	9	0,035	9	12	0,036	12	16	0,038	20	23	0,050	28	31	0,047
70	7	11	0,066	12	15	0,079	18	21	0,070	28	31	0,088	40	43	0,088
100	9	14	0,147	17	21	0,151	25	29	0,161	40	44	0,212	57	61	0,233
125	10	15	0,205	19	23	0,214	28	33	0,236	46	50	0,300	65	70	0,326
150	13	19	0,420	24	30	0,456	36	42	0,505	58	64	0,602	83	89	0,572

MASTER 3 - single branch



- Order number **M3-EA.../.../..**

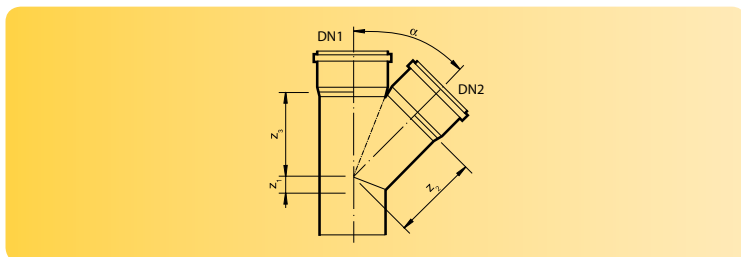

DN1/DN2	$\alpha = 45^\circ$				$\alpha = 67^\circ$				$\alpha = 87^\circ$			
	z_1	z_2	z_3	kg/pcs	z_1	z_2	z_3	kg/pcs	z_1	z_2	z_3	kg/pcs
32/32	10	40	35	0,040					15	30	35	0,040
40/40	10	49	49	0,055	16	33	33	0,049	23	25	25	0,047
50/40	5	56	54	0,064	14	39	35	0,062	23	30	25	0,062
50/50	12	61	61	0,083	20	41	41	0,078	28	30	30	0,074
70/50	-1	79	74	0,102	14	54	46	0,109	27	43	31	0,100
70/70	18	91	91	0,140	26	59	59	0,108	40	43	43	0,118
100/50	-17	104	91	0,261	8	73	54	0,222	28	60	32	0,223
100/70	1	116	109	0,241	22	78	67	0,210	40	60	45	0,205
100/100	25	134	134	0,336	40	86	86	0,342	57	62	62	0,340
125/100	18	144	141	0,451	38	93	89	0,422	58	69	63	0,405
125/125	28	152	152	0,530	46	97	97	0,530	65	70	70	0,530
150/100	1	168	159	0,830	31	112	96	0,668	58	86	64	0,642
150/125	12	176	169	0,920	39	115	104	0,920				
150/150	36	194	194	1,180					83	89	89	1,180

MASTER 3 - double branch



- Order number **M3-DA.../.../..**

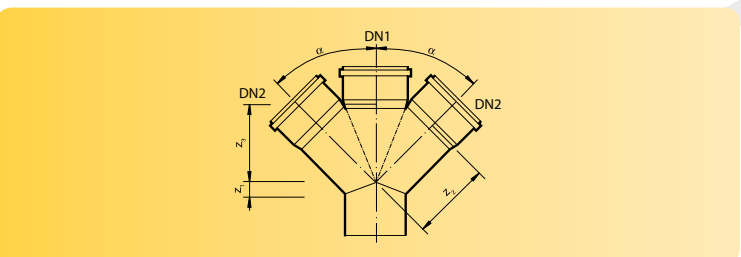

DN1/DN2	$\alpha = 67^\circ$			
	z_1	z_2	z_3	kg/pcs
100/50	8	73	54	0,196
100/100	40	86	86	0,391

MASTER 3 - double corner branch

- Order number **M3-ED.../.../..**

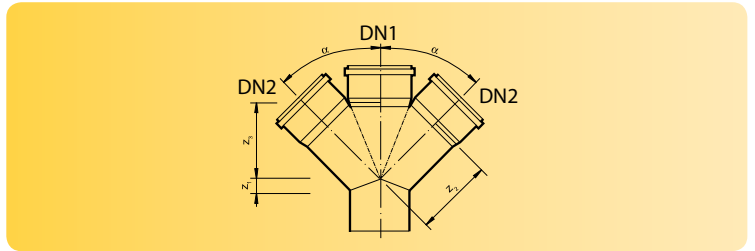

α	45°				87°				
	DN1/DN2	z ₁	z ₂	z ₃	kg/pcs	z ₁	z ₂	z ₃	kg/pcs
100/100		25	134	134	0,450	57	62	62	0,450

MASTER 3 - reducer

- Order number: **M3-R.../...**

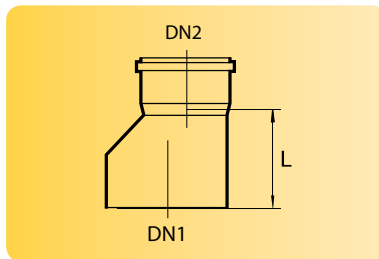

DN1/DN2	z1	kg/pcs
40/32	15	0,020
50/32	15	0,030
50/40	12	0,030
70/40	26	0,051
70/50	20	0,053
100/50	40	0,111
100/70	26	0,117
125/100	15	0,189
150/100	34	0,335
150/125	27	0,336

MASTER 3 - short reducer

- Order number: **M3-R.../...K**

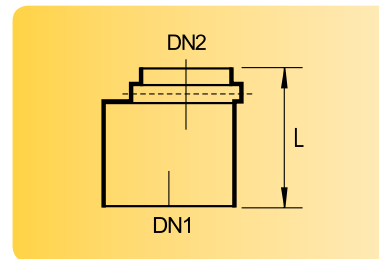

DN1/DN2	L	kg/pcs
50/40	63	0,030
70/50	73	0,053
100/50	90	0,111
100/70	90	0,117

MASTER 3 - acces pipe (with screw-cap and sealing-ring)

- Order number: **M3-RE...**

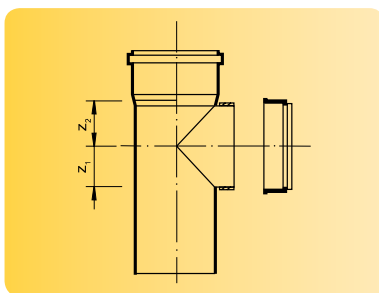

DN	l	kg/pcs
50	146	0,099
70	192	0,200
100	228	0,320
125	236	0,761
150	303	1,06

MASTER 3 - long socket

- Order number: **M3-L...**

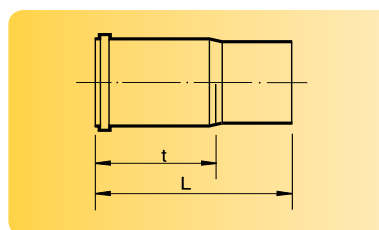

DN	h	t	kg/pcs
40	239	174	0,038
50	163	110	0,052
70	254	183	0,131
100	257	186	0,231

MASTER 3 - repair socket

- Order number: **M3-U...**

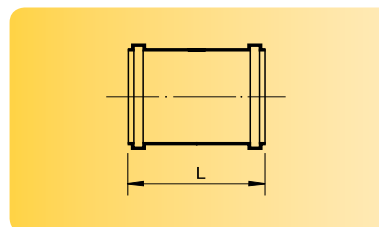

DN	h	kg/pcs
32	100	0,03
40	137	0,03
50	137	0,04
70	144	0,07
100	170	0,15
125	177	0,24
150	196	0,38

MASTER 3 - socket plug

- Order number: **M3-M...**

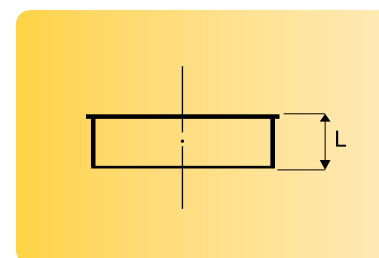

DN	h	kg/pcs
32	33	0,008
40	39	0,010
50	39	0,014
70	39	0,027
100	46	0,068
125	50	0,086
150	58	0,174

MASTER 3 - trap connection socket

- Order number: **M3-S.....**

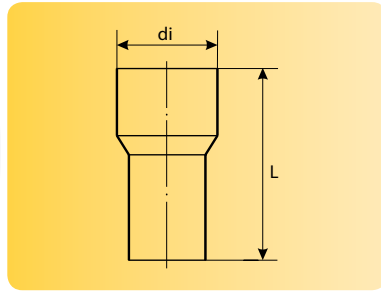

DN	di	L	kg/pcs
32/5/4"+6/4"	53,7	33	0,07
40/5/4"+6/4"	53,7	29	0,03
50/5/4"+6/4"	53,7	30	0,03
50L	60	54	0,04

MASTER 3 - trap connection bend

- Order number: **M3-SW.....**

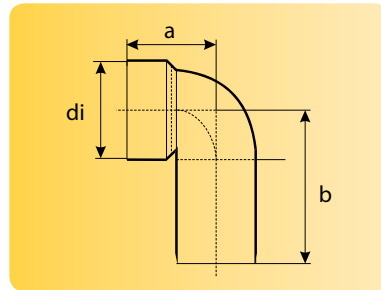

DN	di	a	b	kg/pcs
32/5/4"+6/4"	53,7	54	47	0,08
40/5/4"+6/4"	53,7	57	88	0,03
50/5/4"+6/4"	53,7	51	90	0,04
50L	60	58	93	0,05

Clamp POLO-CLIP

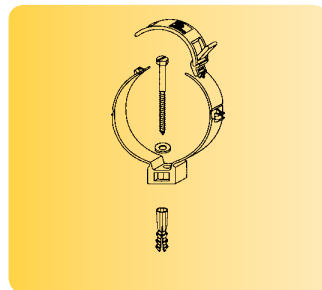

Order number	DN	NUT
M3-CS-A	32/40/50	M8
M3-CS-B	70/100	M10
M3-CS-C	125/150	M10

Set for clamp



Order number

HTCS-3S

Contain: silence element, screw, anchor, wascher

Lubricant tube

- Order number: **MGN0250**
- Volume: 250 g

Lubricant pail

- Order number: **MGN2000**
- Volume: 2000 g

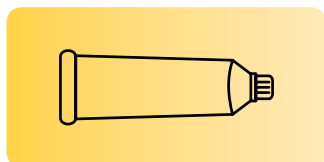

Using of our materials we ask to pay attention to the accordingly valid standards and regulations as well as our company standards and installation guide.

In particular binding are the following standards:

EN 1451 - polypropylene pipe systems for soil for use inside of building's structure

EN 10 53, EN 1054, EN 1055 - thermoplastic pipe systems

EN 12056 - gravitation-drainage-facilities inside of building

Regulations for design and construction

Technical modifications reserved. All details without warranty.

Edition 2012

MASTER

3

MASTER 3 PP multilayer soil system



ISO 9001



ISO 14001



Pipelife International GmbH

Pipelife Austria GmbH & Co KG
IZ NÖ Süd, Strasse 1
Objekt 27
2355 Wr. Neudorf

Your Sales Partner: